

## Angular chucks

Suitable for drilling and screwing in hard-to-reach places - Reduced dimensions

### ◆FISCH®

With shank  $\frac{1}{4}$ " E 6,3 -  $\frac{1}{4}$ " drive

Attachment with quick-release sliding socket for inserting and **automatic expulsion** of the insert or drill

Body in soft non-slip rubber

Movement on ball-bearings

Handle with mounting option both for left and right-handed people

Max rotation speed 2000 rpm - Overall length 140 mm

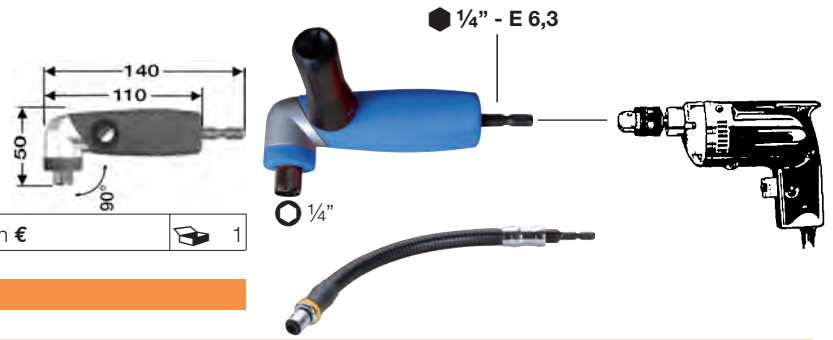

Code E 1121 8000	E 1121/8	Each €		1
------------------	----------	--------	--	---

Flexible extensions with drive  $\frac{1}{4}$ " → A 5 pag. 44

### ABC TOOLS

With 9 mm shank

Aluminium alloy body, with treated gears for long tool life

Movement on ball-bearings

Max rotation speed 2100 rpm - Torque max. 29 N

Gear transmission 1:1,3

Threaded shaft  $\frac{3}{8}$ " x 24 UNF

Overall length 140 mm

Code E 1121 9000	E 1121/9	Each €		1
------------------	----------	--------	--	---

Version with keyless chuck, opening 1,5÷10 mm

Overall length 147 mm

Code E 1121 9300	E 1121/93	Each €		1
------------------	-----------	--------	--	---

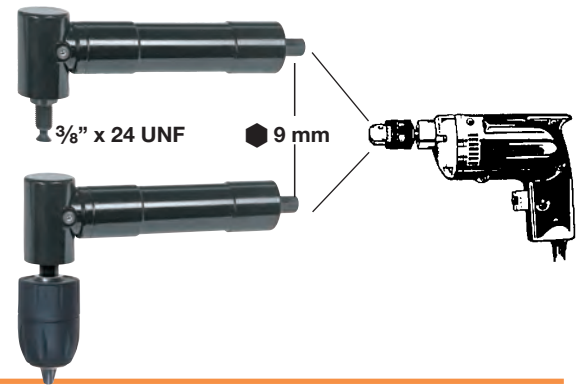

E 5

## ABC TOOLS Drill adapters

With hexagonal shank  $\frac{1}{4}$ " E 6,3 and threading  $\frac{3}{8}$ " x 24 UNF

For drills and screwdrivers - Overall length 40 mm

Code E 1122 0000	E 1122/0	Each €		1
------------------	----------	--------	--	---



Type with SDS-plus shank and threading  $\frac{1}{2}$ " x 20 UNF

For drilling without impact movement - Overall length 60 mm

Code E 1122 2000	E 1122/2	Each €		1
------------------	----------	--------	--	---



Type with two male threadings -  $\frac{1}{2}$ " x 20 e  $\frac{3}{8}$ " x 24 UNF

Suitable for chucks with internal coupling  $\frac{1}{2}$ " x 20 UNF

Overall length 26 mm

Code E 1123 3000	E 1123/3	Each €		1
------------------	----------	--------	--	---



Type with one male and one female threading -  $\frac{1}{2}$ " x 20 -  $\frac{3}{8}$ " x 24 UNF

Suitable for chucks with internal coupling  $\frac{1}{2}$ " x 20 UNF

Overall length 15 mm

Code E 1123 4000	E 1123/4	Each €		1
------------------	----------	--------	--	---



Bit holders → A 5 pag. 44



## ABC TOOLS Morse taper drill chuck arbors

In special steel

For chucks with DIN 238/2 conical attachment

G 900/1 - Standard version

G 900/2 - Precision version, entirely tempered and ground



Size	11	21	22	31	32	33	34	41	42	43	44	52	53	54	63	64
Code G 0900 ...	—	1021	—	1031	1032	1033	1034	—	1042	1043	1044	—	—	—	—	—
G 900/1	Each €															
Code G 0900 ...	2011	2021	2022	2031	2032	2033	2034	2041	2042	2043	2044	2052	2053	2054	2063	2064
G 900/2	Each €															
Attachment DIN 238/1	B 10	B 12	B 12	B 16	B 16	B 16	B 16	B 18	B 18	B 18	B 18	B 22	B 22	B 22	B 24	B 24
Max taper Ø DIN 238	10,095	12,065	12,065	15,733	15,733	15,733	15,733	17,780	17,780	17,780	17,780	21,793	21,793	21,793	23,825	23,825
Morse taper	1	1	2	1	2	3	4	1	2	3	4	2	3	4	3	4

G 2 → pag. 590