

Using lathe tools

For prompt identification and easy consultation of lathe tools present on the following pages.

1	F 777/22 - F 777/23 ISO 6
2	F 777/12 - F 777/13 ISO 2
3	F 777/20 - F 777/21 ISO 4
4	F 777/10 - F 777/11 ISO 1
5	F 777/18 - F 777/19 ISO 10
6	F 777/24 - F 777/25 ISO 7
7	F 777/26 ISO 12
8	F 777/30 - F 777/31 ISO 3
9	F 710/1 Type PSSNR 2020-12
10	F 714/1 Type PWLNR 2020-08K
11	F 724/1 Type PTNn
12	F 718/1 Type PER 2020K-16K
13	F 712/1 Type PCLNR 2525-12
14	F 716/1 Type PCLNR 2525-12
15	F 720/1 Type SCLCR-06

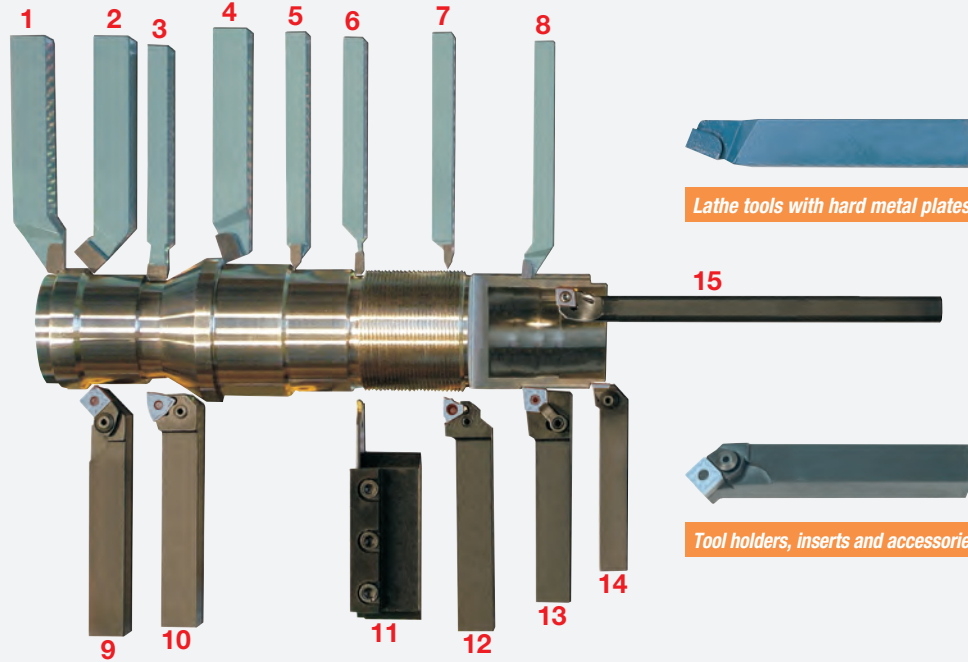

Lathe tools with hard metal plates from page 485

Tool holders, inserts and accessories from page 482

Lathe tools

In tool steel - Right-hand version - Overall length 125 mm

TOOL HOLDER FOR NEGATIVE INSERTS (0°)

With clamp - With plate, clamp, pin, screw and wrench

Version for 45° external turning - Model PSSNR 2020-12 - Shank 20x20 mm

Code F 0710 1000	F 710/1	Without insert	Each €		1
------------------	----------------	----------------	--------	--	---

F 710/4 - Carbide insert with TiCN coating - Shape SNMG 120408 SSP

F 710/3 - Spare plate

Code F 0710 4000	F 710/4	Insert*	Each €		10
Code F 0710 3000	F 710/3	Plate	Each €		10

Version for 90° external turning - Without inserts - Shank 20x20 mm

Cutting direction	Vertical	Horizontal
Code	F 0711 1001	F 0711 1002
F 711/1	Each €	
Type	PTGNR 2020-16	PTFNR 2020-16

F 711/4 - Carbide insert with TiCN coating - Shape TNMG 160408 SSP

F 711/3 - Spare plate

Code F 0711 4000	F 711/4	Insert*	Each €		10
Code F 0711 3000	F 711/3	Plate	Each €		10

Version for 95° external turning - Model PCLNR 2525-12 - Shank 25x25 mm

Code F 0712 1000	F 712/1	Without insert	Each €		1
------------------	----------------	----------------	--------	--	---

F 712/4 - Carbide insert with TiCN coating - Shape CNMG 120408 SSP

F 712/3 - Spare plate

Code F 0712 4000	F 712/4	Insert*	Each €		10
Code F 0712 3000	F 712/3	Plate	Each €		10

Spare clamps for tool holder

Size	1	2
Code	F 0713 5001	F 0713 5002
F 713/5	Each €	
Suitable for	F 711/1 size 1	F 710/1-F 711/1 size 2-F 712/1

Spare accessories for tool holders F 710/1 - F 712/1

Code F 0713 6000	F 713/6	Pin	Each €		5
Code F 0713 7000	F 713/7	Screw	Each €		5

* Inserts are sold in indivisible packs of 10 pcs.

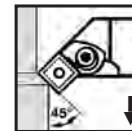

F 710/4 - Insert



F 710/3 - Plate

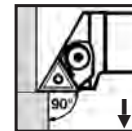

vertical direction

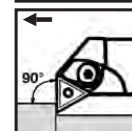

horizontal direction



F 711/4 - Insert



F 711/3 - Plate

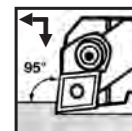

F 712/4 - Insert



F 712/3 - Plate



F 713/6



F 713/7