

JUWEL Dial calipers

In stainless steel, tempered - Accuracy DIN 862
Screw locking type and individual identification number
Individually checked and tested - Supplied with case

Type with 1/50 mm (0,02 mm) graduation

With flat rod and adjustment roller
Rotating dial Ø 35 mm, with lock and 1 pointer - **One turn of the pointer = 2 mm**

Measuring range	mm	150	200	300
Code		H 4213 1150	H 4213 1200	H 4213 1300
H 4213/1	Each €			
Jaw length	mm	40	45	60

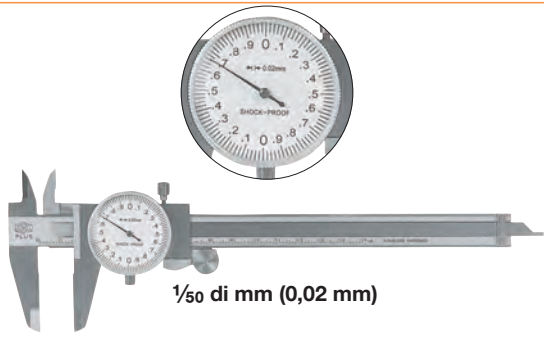

1/50 di mm (0,02 mm)

1/100 mm (0,01 mm) graduation

Graduated flat rod with **matt chromed, non-reflective** surface
Protected rack against dust and dirt infiltrations - With adjustment roller
Rotating dial Ø 38 mm, with lock and 1 pointer

Measuring range 150 mm - Jaws length 40 mm
One turn of the pointer = 1 mm

Code H 4213 4150	H 4213/4	Each €		1
------------------	----------	--------	--	---

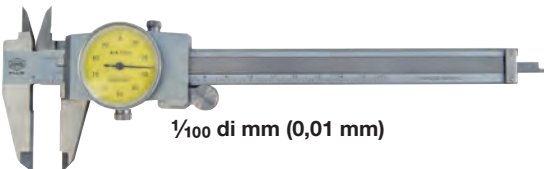

1/100 di mm (0,01 mm)

ABC TOOLS Vernier calipers in synthetic resin

Non-magnetic
Suitable for the electronic field (they do not conduct electricity), automotive, fishing and nautical industries etc.

With 1/100 mm (0,01 mm) graduation - .0005 inches - Accuracy ±0,02 mm

With flat rod - Optimized vernier scale sliding
ON/OFF, ZERO, mm/inch function
Measuring range 150 mm - Jaws length 40 mm
Wide LCD display with figures 13 mm in height, in carbon glass fiber
Individually checked and tested

Code H 4214 1150	H 4214/1	Each €		1
------------------	----------	--------	--	---



1/100 mm (0,01 mm) - .0005 inches

JUWEL Digital calipers

In stainless steel, tempered - Accuracy DIN 862
With 1/100 mm (0,01 mm) graduation - .0005 inches
Highest level of accuracy, even at high speed sliding movements
Jaws with tips for measuring small grooves and slots
Screw locking and individual identification number
Individually checked and tested - Supplied with case

Type with wide, easy to read, 5-digit 11 mm display
ON/OFF, ZERO, mm/inch function - Scale graduated in mm and inches
With data output - SR-44 battery powered

Measuring range	mm	150	200	300
Code		H 4215 4150	H 4215 4200	H 4215 4300
H 4215/4	Each €			
Jaw length	mm	40	40	65

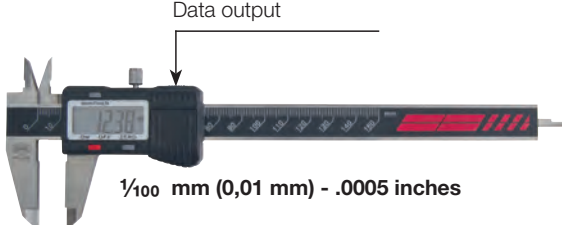

1/100 mm (0,01 mm) - .0005 inches

Type with metal chromed pointer with high quality function buttons
Vernier scale protected against dust penetration
ON/OFF, ZERO, mm/inch functions - Accuracy ±0,03 mm
With data output (except sz. 100 mm) - Wide, 5-digit 8,5 mm display
CR-2032 battery powered

H 4216 - Flat depth rod
H 4216/1 - Round depth rod Ø 1,9 mm

Measuring range	mm	100	150	200
Code		H 4216 0100	H 4216 0150	H 4216 0200
H 4216	Each €			
Code		—	H 4216 1150	—
H 4216/1	Each €			
Jaw length	mm	35	40	50

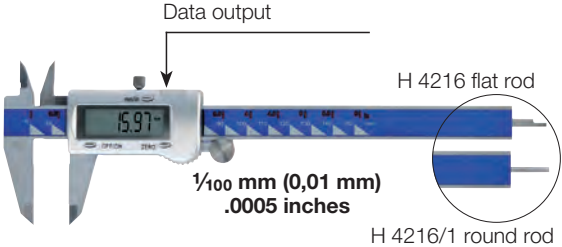

1/100 mm (0,01 mm) .0005 inches

Type with protection level IP 67 against the penetration of dust and the effects of temporary immersion
For use in workshops or working environments where they have to resist to liquids and coolants
ON/OFF, ZERO, mm/inch functions - Accuracy ±0,03 mm
Wide, 5-digit 8,5 mm display - Automatic switch off after about 5 min
CR-2032 battery powered

IP 67

Measuring range	mm	150	200	300
Code		H 4216 6150	H 4216 6200	H 4216 6300
H 4216/6	Each €			
Jaw length	mm	40	50	60



1/100 mm (0,01 mm) - .0005 inches